



# पुर्णा International School

Shree Swaminarayan Gurukul, Zundal

Class – XII

Subject: PHYSICS

Experiment(2026-27)

Exp. No	Date	Aim
		<b><u>Section – A</u></b>
1		To determine resistivity of two / three wires by plotting a graph for potential difference versus current.
2		To find resistance of a given wire / standard resistor using metre bridge.
3		To determine resistance of a galvanometer by half-deflection method and to find its figure of merit.
4		To convert the given galvanometer (of known resistance and figure of merit) into a voltmeter of desired range and to verify the same.
		<b><u>Section – B</u></b>
5		To find the focal length of a convex lens by plotting graphs between $u$ and $v$ or between $1/u$ and $1/v$ .
6		To find the focal length of a convex mirror, using a convex lens.
7		To determine angle of minimum deviation for a given prism by plotting a graph between angle of incidence and angle of deviation.
8		To draw the I-V characteristic curve for a p-n junction diode in forward bias and reverse bias.
		<b><u>Activities</u></b>
1		To measure resistance, voltage (AC/DC), current (AC) and check continuity of a given circuit using multimeter.
2		To assemble a household circuit comprising three bulbs, three (on/off) switches, a fuse and a power source.
3		To assemble the components of a given electrical circuit.
4		To identify a diode, an LED, a resistor and a capacitor from a mixed collection of such items.
5		To study effect of intensity of light (by varying distance of the source) on an LDR.
6		To observe diffraction of light due to a thin slit.

## EXPERIMENT – 1

### Aim

To determine the resistance per cm of a given wire by plotting a graph for potential difference versus current.

### Apparatus/Material Required

- A wire of unknown resistance
- Battery
- Voltmeter
- Milliammeter
- Rheostat
- Plug key
- Connecting wires
- Piece of sandpaper

### Circuit Diagram

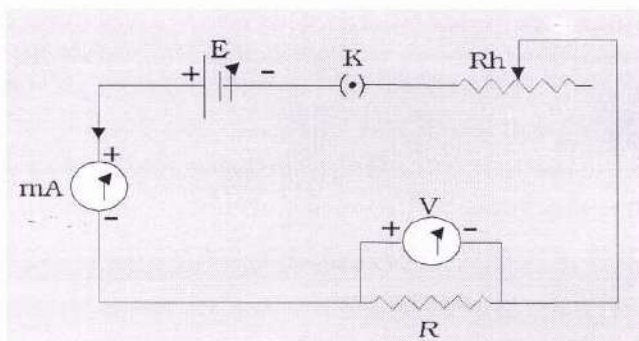

### Theory

According to Ohm's law,

the electric current flowing through a conductor is directly proportional to the potential difference across its ends, provided the physical state (pressure, temperature, and dimensions) of the conductor remains unchanged.

$$V = RI$$

[If  $I$  is the current flowing through the conductor and  $V$  is the potential difference across its end.]

Where  $R$  is the constant of proportionality and is termed as the electrical resistance of the conductor. Resistance  $R$  depends on the dimensions and material of the conductor.

The relationship between the resistance of a material ( $\rho$ ) and its length ( $l$ ) and area of the cross-section ( $A$ ) is given by the formula,

$$R = \rho \frac{l}{A}$$

### Procedure

1. Clean the ends of the connecting wire with the help of sandpaper to remove any insulating coating on them.
2. Connect the resistance, rheostat, battery, key, voltmeter, and ammeter as shown in the figure.
3. Make sure that the pointers in the voltmeter and milliammeter coincide with the zero mark on the measuring scale. If not, adjust the pointer to coincide with the zero mark by adjusting the screw provided at the base using a screwdriver.
4. Note the range and the least count of the given voltmeter and milliammeter.
5. Insert the key K and slide the rheostat to the end where the current flow is minimum.
6. Note the voltmeter and the milliammeter reading.
7. Remove the key K and allow the wire to cool. Again insert the key and slightly increase the voltage by moving the rheostat. Note down the milliammeter and voltmeter reading.
8. Repeat step 7 for four different adjustments of the rheostat. Document the readings in a tabular column.

### Observations

Range of ammeters = 0 mA to 500 mA

The Least count of ammeter = 10 mA

Range of voltmeter = 0 V to 5 V

The Least count of voltmeter = 0.1 V

The Least count of meter-scale = 0.1 cm

Length of the given wire,  $l =$  1 m

### Observation Table

Sr. No	Voltmeter Reading (V)	Milli-Ammeter Reading (mA)	$R = \frac{V}{I}$ ( $\Omega$ )
1	0.1	0.3	0.33
2	0.2	0.7	0.28
3	0.3	1.1	0.27
4	0.4	1.5	0.26
5	0.5	1.9	0.26

## Calculations

1. Plot a graph between the potential difference across the wire  $V$  and the current  $I$  flowing through the wire as shown below.

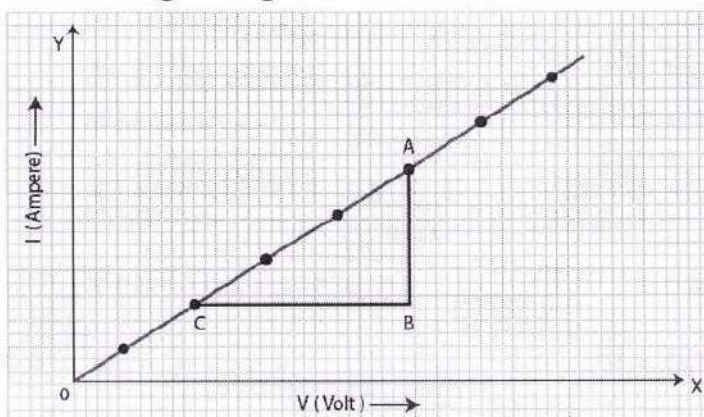

2. Determine the slope of the graph. The resistance of the given wire is then equal to the Reciprocal of the slope.
3. From the graph,  $R = \frac{BC}{AB} = \underline{0.25} \Omega$
4. Resistance per unit length of the wire  $= \frac{R}{l} = \underline{0.25} \Omega \text{ m}^{-1}$

## Error

Here,  $R$  is the resistance per unit length and  $\Delta R$  is the estimated error.  $\Delta V$  And  $\Delta I$  are the least count of voltmeter and ammeter respectively.

## Result

The potential difference across the wire varies linearly with the current.

The resistance per unit length of the wire is  $(R \pm \Delta R) = \underline{0.25} \pm \underline{0.52} \Omega \text{ m}^{-1}$ .

## Precautions

1. The voltmeter should be connected in parallel and the ammeter in series with the circuit. It should be ensured that current enters at the positive terminal and leaves at the negative terminal.
2. The key should be inserted only while taking observations, as excessive flow of current causes unnecessary heating of the wire.
3. Zero error in measuring instruments (voltmeter, ammeter, metre scale) must be taken cognizance of and should be eliminated in case of ammeter and voltmeter by adjusting the pointer with the help of the screw provided at the base of the needle, using a screw driver.

## Sources of Error

1. The wire used may not be of uniform area of cross-section.
2. The length of the resistance wire measured should be between one terminal of voltmeter and the other. The lengths of ends wound around the terminals of voltmeter, if included, would give error in measured length.

## EXPERIMENT – 2

### Aim

To find resistance of a given wire using a metre bridge and hence determine the resistivity (specific resistance) of its material.

### Materials Required

- A metre bridge
- A battery eliminator
- A galvanometer
- A resistance boxes
- A jockey
- A one-way key
- A resistance wire
- A screw gauge
- A metre scale
- Connecting wires

### Theory

Metre bridge apparatus is also known as a slide wire bridge. It is fixed on the wooden block and consists of a long wire with a uniform cross-sectional area. It has two gaps formed using thick metal strips to make the Wheatstone's bridge.

Then according to Wheatstone's principle, we have:

$$\frac{X}{R} = \frac{l}{(100-l)}$$

The unknown resistance can be calculated as:

$$X = R \frac{l}{(100-l)}$$

Then the specific resistance of the material of the given wire is calculated as:

$$\rho = \frac{AX}{L} \text{ (where, } A = \pi r^2 \text{ cross-section of wire and } r \text{ is the radius of the wire)}$$

Where, L is the length of the wire.

## Circuit Diagram

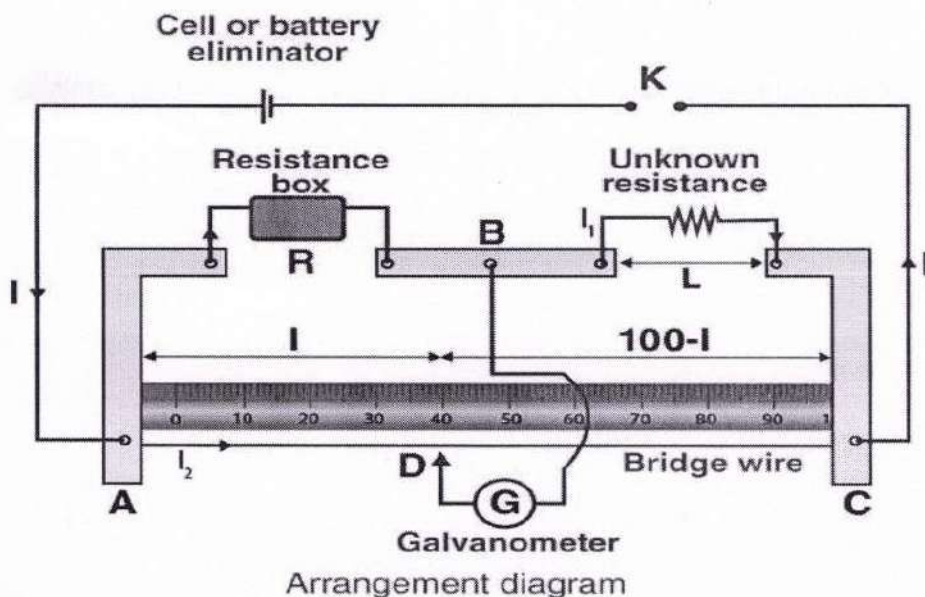

Arrangement diagram

## Procedure

1. The arrangement of the apparatus should be as shown in the circuit diagram.
2. The wire whose resistance is to be determined should be connected in the right gap between C and B without any formation of loops.
3. The resistance box should be connected in the left gap between A and B.
4. All the other connections should be as shown in the circuit diagram.
5. Plug the key K in place of  $2 \Omega$  resistance in the resistance box.
6. The jockey should be first touched gently to the left end and then to the right end of the bridge.
7. The deflections in the galvanometer should be in opposite directions and if it is in one direction then the circuit connections are not correct. Note the galvanometer deflection.
8. Let D be the null point where the jockey is touching the wire. The movement of the jockey should be gentle from left to the right of the galvanometer.
9. Take a 12 value from the resistance box should be taken such that when the jockey is nearly in the middle of the wire, there shouldn't be any deflection.
10. Note the position of D to know the length of  $AD = l$ .
11. Four sets of observations should be taken by changing the value of Resistance R.
12. Record the observations in a tabular form.
13. Stretch the resistance wire to find its length using a metre scale.
14. Using screw gauge measure the diameter of the wire at four different places keeping it in a mutually perpendicular direction.
15. Record the observations in the table.

## Observations

Length of given wire  $L = 100$ .cm

**Table for unknown resistance (X)**

Sr. No	Resistance from box, R (Ohm)	Length AB = l (cm)	Length BC = (100-l) (cm)	Unknown Resistance X = $[R(100-l)]/L$ (Ohm)
1	0.5	58.3	41.7	0.35
2	0.7	60.7	39.3	0.45
3	1	61.9	38.1	0.65
4	1.5	61.1	38.9	0.95
5	1.5	61.1	38.9	0.95

$$Mean = 0.59 \Omega$$

**Least count of the screw gauge**

Pitch of screw gauge = ...2...mm

Total no. of divisions on the circular scale = 100

$\therefore$  L.C. of the given screw gauge = 0.02 mm

Zero error e = ...... mm

Zero correction c = -e = ...... mm

**Radius of the resistance wire**

Sr No.	Main scale reading (mm)	Circular scale reading	Total reading (diameter) (mm)	Mean D (mm)	Mean radius (D/2) (mm)
1	0	43	0.43	0.43	0.215
2	0	42	0.42	0.42	0.21
3	0	43	0.43	0.43	0.215

$$Mean = 0.21 \text{ mm}$$

**Calculations**

**Calculation for X**

The value of R is determined from the position of null point D and record length in Table.

Find length (100 - l) cm and note-down in Table.

$$Mean X = \frac{X_1 + X_2 + X_3 + X_4 + X_5}{5} = \underline{0.59} \Omega$$

## Calculation for D

$$\text{Mean corrected diameter} = \frac{D_1 + D_2 + D_3}{3} = 0.21 \text{ mm} = 2.1 \text{ cm}$$

## Calculation for specific resistance

Specific resistance of the material of the given wire,

$$\rho = \frac{AX}{L} \quad (\text{Where } A = \pi r^2 \text{ or } \frac{\pi d^2}{4}) = 3.14 \times \frac{2.1 \times 2.4}{4} \times 0.59 = 2.042 \times 10^{-3} \Omega \text{ m}$$
$$= 0.2042 \times 10^{-3} \Omega \text{ m}$$

Standard value of the specific resistance of the material of the given wire,  $\Omega \text{ m}$

$$\rho_0 = \dots \Omega \text{ m} = 0.2042 \times 10^{-3} \Omega \text{ m}$$

$$\text{Percentage error} = \left( \frac{\rho - \rho_0}{\rho_0} \right) \times 100 = \dots \%$$

## Result

1. The value of unknown resistance  $X = 0.59 \Omega$
2. The specific resistance of the material of the given wire  $= 0.2042 \times 10^{-3} \Omega \text{ m}$
3. Percentage error =  $\dots \%$

## Precautions

1. The connections should be neat, tight and clean.
2. Plugs should be tightly connected in the resistance box.
3. The movement of the jockey should be gentle and it shouldn't be rubbed.
4. The key K should be inserted only when the observations are to be taken.
5. The null point should be between 45cm and 55cm.
6. To avoid the error of parallax, the set square should be used to note the null point.
7. There shouldn't be any loops in the wire.
8. The diameter of the wire should be measured in two perpendicular directions that are mutual.

## Sources of Error

1. The screws of the instrument might be loose.
2. The wire might be of non-uniform diameter.
3. There might be backlash error in the screw gauge.

## EXPERIMENT – 3

### Aim

To determine the resistance of a galvanometer by a half-deflection method and to find its figure of merit.

### Apparatus/Materials Required

- A battery
- A Weston type galvanometer
- Two one-way keys
- Rheostat
- Screw gauge
- Metre-scale
- Ammeter
- Connecting wires
- A piece of sandpaper
- Two resistance boxes

### Circuit Diagram

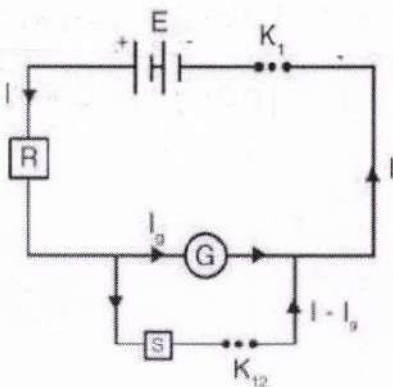

Resistance of galvanometer

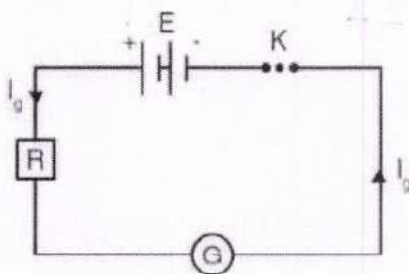

Figure of merit

### Procedure

1. Connect the circuit as shown in the figure.
2. Make sure that all the plugs in the resistance boxes are tight.
3. From the high resistance box ( $R_{\text{BOX-1}}$ ) (1-10 k $\Omega$ ), remove 5 k $\Omega$  key and then close the key K1. Adjust the resistance R from this resistance box to get full scale deflection on the galvanometer dial. Record the values of resistance, R and deflection  $\theta$ .

4. Insert the key K2 and keep R fixed. Adjust the value of shunt resistance S to get the deflection in the galvanometer which is exactly half of  $\theta$ . Note down S. Remove plug K2 after noting down the value of shunt resistance, S.
5. Take five sets of observations by repeating steps 2 and 3 so that  $\theta$  is even number of divisions and record the observations for R, S,  $\theta$  and  $\theta/2$  in tabular form.
6. Calculate the galvanometer resistance G and figure of merit k of galvanometer using equations.

### Observations Table

Emf of the battery E =  $6.49$  V

Number of divisions on full scale of galvanometer =  $30$

Sr. No.	Resistance R	Deflection in the Galvanometer $\theta$	Half Deflection $\theta/2$	Shunt Resistance S	Galvanometer Resistance $G = \frac{RS}{R-S}$	Figure of merit $K = \frac{E}{(R+G)\theta}$
1	10,000	28	14	100	101	$2.2 \times 10^{-5}$
2	11,000	26	13	100	100.9	$2.2 \times 10^{-5}$
3	12,500	24	12	100	100.8	$2.1 \times 10^{-5}$
4	14,000	22	11	100	100.7	$2 \times 10^{-5}$

### Calculations

The number of divisions in the galvanometer scale, n =  $30$ .

#### 1. Calculation for G

- Using the formula

$$G = \frac{RS}{R-S}, \text{ calculate G and note it down.}$$

- Take the mean of the value of G.

#### 2. The calculation for k

- Using the formula

$$K = \frac{E}{(R+G)\theta}, \text{ calculate the value of k and write it.}$$

- Take the mean value of k and record it.

## Result

1. The resistance of the given galvanometer by half deflection method,  $G = 100 \Omega$ .
2. The figure of merit of a given galvanometer,  $k = \frac{2 \times 10^{-5}}{20 \mu A} \text{ A/division}$ .

## Precautions

1. Key K1 should be inserted only after high value of R has been taken out from resistance box otherwise galvanometer coil may burn.
2. Adjust R such that deflection in galvanometer is of even division so that  $\theta/2$  is more conveniently obtained.
3. Emf of the battery should be constant.
4. Use as high values of R as practically possible. This ensures correct value of G.
5. All the connections and plugs in the resistance box should be tight.

## Sources of Error

1. Plugs in the resistance boxes may be loose or they may not be clean.
2. The emf of the battery may not be constant.

Calculations:-

$$(1) \quad G = \frac{RS}{R-S}$$

$$G_1 = \frac{10,000 \times 100}{10,000 - 100} = 101 \Omega$$

$$G_2 = \frac{11,000 \times 100}{11,000 - 100} = 100.9 \Omega$$

$$G_3 = \frac{12,1500 \times 100}{12,1500 - 100} = 100.8 \Omega$$

$$G_4 = \frac{14,500 \times 100}{14,500 - 100} = 100.7 \Omega$$

$$(2) \quad K = \frac{E}{(R+G)\theta}$$

$$\star K_1 = \left( \frac{6.49}{10,000 + 101} \right) \cdot \frac{1}{28} \\ = \underline{2.2 \times 10^{-5} \text{ A/division}}$$

$$\star K_2 = \left( \frac{6.49}{10,000 + 100.9} \right) \cdot \frac{1}{26} \\ = \underline{2.2 \times 10^{-5} \text{ A/div.}}$$

$$\star K_3 = \left( \frac{6.49}{12,1500 + 100.8} \right) \cdot \frac{1}{24} \\ = \underline{2.1 \times 10^{-5} \text{ A/div}}$$

$$\star K_4 = \left( \frac{6.49}{14,000 + 100.7} \right) \cdot \frac{1}{22} \\ = \underline{2.1 \times 10^{-5} \text{ A/div}}$$

## EXPERIMENT – 4

### Aim

To convert the given galvanometer (of known resistance and figure of merit) into a voltmeter of desired range and to verify the same

### Apparatus Required

- A galvanometer
- A voltmeter 0-3V
- Battery
- 2 resistance box (10,000  $\Omega$  and 200  $\Omega$ )
- 2 one-way keys
- A rheostat
- connecting wires and sandpaper

### Theory

By connecting a high resistance of suitable value in series with a galvanometer, it is converted into a voltmeter. Voltmeter is always connected in parallel with the electrical component across which potential difference is to be measured.

If a galvanometer (having resistance  $G$ ) shows a full-scale deflection for a maximum current  $I_g$ , the potential difference across the galvanometer is  $I_g \cdot G$ .

If the converted galvanometer is desired to have a range  $V_0$  volt, then the resistance to be joined in series with galvanometer, is given by,  $V = \frac{V_0}{I_g} - G$

V-range of conversion

### Circuit Diagram

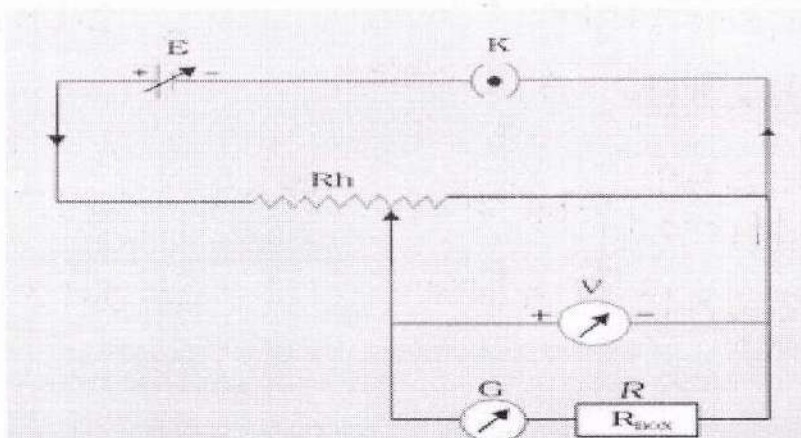

Circuit to verify conversion of galvanometer into a voltmeter

## Procedure

1. Connect resistance box in series combination with the galvanometer and take the plugs of resistance R.
2. Calculate the value of the series resistance R for given values of  $V_0$ ,  $I_g$  and G.
3. Now the galvanometer functions as a voltmeter of range 0-V Volts.
4. Take out the plugs of calculated resistance R from the resistance box.
5. By using a key adjust the movable contact of the rheostat such that the deflection of the galvanometer becomes maximum.
6. Note both the readings of the galvanometer and voltmeter.
7. Convert the readings of the galvanometer into volts.
8. Find the difference in the reading. This difference between voltmeter reading and galvanometer reading gives the error.
9. By moving the variable contact of rheostat take 5 readings covering the range of voltmeters from 0-3 Volts.

## Observations and Calculations

The resistance of the given galvanometer  $G = 100 \Omega$

The figure of merit  $k$  (given) =  $2 \times 10^{-5}$  ampere/division

Number of divisions in galvanometer scale  $n = 30$

Current for full scale deflection =  $I_g = n k = 0.6 \text{ A}$

Range of conversion =

= Desired range of  
voltmeter

Resistance to be placed in series with galvanometer  $R = \frac{V}{I_g} - G = 3 \text{ V}$

## Observation Table

The Least count of galvanometer converted into voltmeter =  $V/n = \frac{3 \text{ V}}{30} = 0.1 \text{ V}$

Sr. No.	Reading of galvanometer into voltmeter		Standard voltmeter reading $V_2$	Standard voltmeter reading $V_2 - V_1$
	Deflection ( $\theta$ )	The potential difference in volts $V_1$		
1	10	1	1	0
2	15	1.5	1.5	0
3	20	2	2	0

## Result

To convert the given galvanometer into a voltmeter of the range, 0 to 3.0 V

1. The value of the calculated series resistance,  $R = 4900 \Omega$
2. The value of the observed series resistance,  $R' = 4800 \Omega$
3. Current for full scale deflection,  $I_g = 0.6 \text{ mA}$

## Precautions

- The resistance box used should be of high resistance.
- The rheostat should be used as potential divider.
- High resistance of the order of  $10 \text{ k}\Omega$  from the resistance box should be used first and then the battery key should be closed to avoid any damage to the galvanometer.

## Sources of Error

- The wire may be of non-uniform area of cross section.

$$\begin{aligned} R &= \frac{V}{I_g} - G \\ &= \frac{3}{0.6 \text{ mA}} - 100 \\ &= \frac{3000}{0.6} - 100 \end{aligned}$$

$$\therefore R = 4900 \Omega$$

## EXPERIMENT – 5

### Aim

To find the focal length of a convex lens by plotting graphs between  $u$  and  $v$  or between  $1/u$  and  $1/v$ .

### Materials Required

- One optical bench
- Metre scale
- Index needle or a knitting needle
- Three uprights (with clamps)
- A convex lens of less than 20 cm focal length
- Two sharp-edged needles
- Spirit level

### Theory

For a body positioned at a distance ' $u$ ' from the optical centre of a thin convex lens of focal length ' $f$ ', an inverted and real image is generated on the lens's other side at a distance ' $v$ ' from the optical centre. The relationship between these quantities is:

$$\frac{1}{f} = \frac{1}{v} - \frac{1}{u}$$

From this equation, the focal length is,

$$\frac{1}{f} = \frac{u-v}{uv}$$
$$f = \frac{uv}{u-v}$$

### Ray Diagram

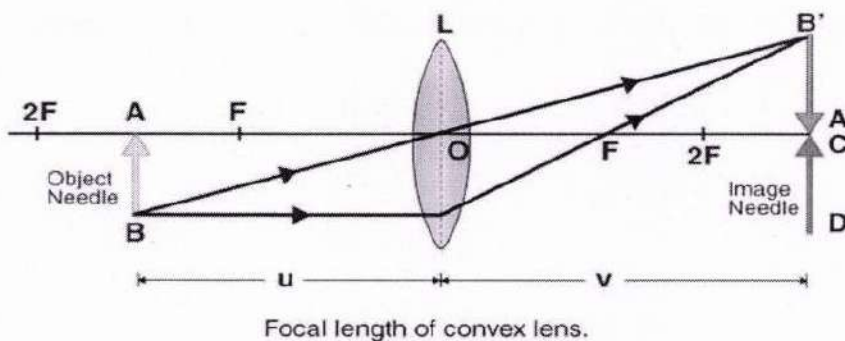

## Procedure

1. Fix the convex lens in the holder.
2. Use the lens to focus an object like a tree on a white screen or a wall.
3. Precisely focus the image of the object on the wall or screen until a sharp image is obtained.
4. Calculate the distance between the lens and the wall or screen. It will be the rough focal length of the lens.
5. Mount the holder with the lens in a locked upright, and place the upright at the 50cm mark.
6. Tune the orientation of the lens in such a way that its surface is perpendicular and vertical to the optical bench's length.
7. Maintain the upright fixed in the above position throughout.
8. Use the thin optical needle as the object (O). Fix it in the outer, laterally movable upright close to zero ends.
9. Adjust the object needle upright, and place it at a distance close to 1.5 times the acquired approximate focal length of the lens.
10. Tune the height of the object needle to adjust its tip to lie on the horizontal plane through the lens's optical centre. Record the position of the index mark on the foot of the object needle upright.
11. Close your right eye, and open the left eye. Then watch from the other terminal of the optical bench. The image's tip should be present in the middle of the lens.
12. Place the thick optical image needle in the fourth upright close to the other terminal of the optical bench.
13. Tune the height of the image needle in a way that its tip is visible in line with the image's tip when seen with the left eye open.
14. Look towards the right. The tips will be separated. The image needle tip and the image tip have parallax. Clear the parallax tip to tip.
15. Record the position of the index mark on the foot of the image needle upright.
16. Note down the position of the index mark on the foot of the upright of the lens, the image needle, and the object needle in the second observation column.
17. Calculate the index correction for length between the tip of the object needle and the optical centre of the lens. Next, find the distance between the tip of the image needle and the optical centre of the lens, as mentioned.
18. Adjust the object needle upright towards the mirror in steps 1cm to obtain observations 1 and 2. Repeat the process.
19. Adjust the object needle upright away from the mirror in steps of 1cm to obtain observations 6, 5, and 4.
20. Note down all the observations as shown ahead.

## Observations

- The rough or approximate focal length of the convex lens = ...16... cm

## Observations Table

Serial no. of obs (1)	Position of			Observed distance		Corrected distance		$\frac{1}{u}$ (cm <sup>-1</sup> ) (5)	$\frac{1}{v}$ (cm <sup>-1</sup> ) (6)
	Object needle A (cm) (2a)	Lens O (cm) (2b)	Image needle C (cm) (2c)	OA = u (cm) (3a)	OC = v (cm) (3b)	u (cm) (4a)	v (cm) (4b)		
1.	66	50	26	16	24	16	24	0.062	0.041
2.	67	50	27	17	23	17	23	0.058	0.043
3.	68	50	28	18	22	18	22	0.055	0.045
4.	70	50	30	20	20	20	20	0.05	0.05
5.	75	50	33	23	17	23	17	0.053	0.058
6.	80	50	34	24	16	24	16	0.041	0.062

## Calculation

Calculation of the focal length by the graphical method:

### 1) $v \rightarrow u$ Graph

Choose a suitable but the same scale to denote  $v$  along the Y-axis and  $u$  along X-axis.

As per sign conventions,  $v$  is positive, and  $u$  is negative.

Plot the points for different rates of  $v$  and  $u$  from the observation table in the second section. The graph is a rectangular hyperbola, as represented in the graph between  $u$  and  $v$ .

Draw a line OA creating an angle of  $45^\circ$  with either axis bisecting  $\angle YOX'$  and reaching the curve at point A. Draw AC and AB perpendicular on the Y and X'-axis, respectively.

The values of  $v$  and  $u$  are the same for point A. The coordinates of point A should be  $(2f, 2f)$ , as for a convex lens, when  $v = 2f$ ,  $u = 2f$ .

Therefore,  $AB = AC = 2f$  or  $OB = OC = 2f$

This implies that  $f = OB/2$  and  $f = OC/2$

Mean value of  $f = 10.1$  cm

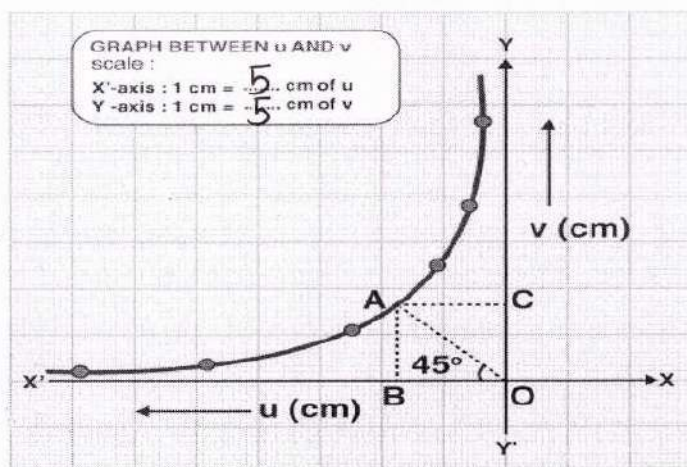

## 2) $\frac{1}{v} \rightarrow \frac{1}{u}$ Graph

Choose an apt but the same scale to denote  $1/u$  along the X'-axis and  $1/v$  along the Y-axis. As per sign conventions,  $1/u$  is negative, and  $1/v$  is positive.

Plot the points for varied sets of values of  $1/u$  and  $1/v$  from the observation table. The graph evolves to be a straight line as represented in the graph between  $1/v$  and  $1/u$ .

The straight-line slices the two-axis OY and OX' at an angle of  $45^\circ$  at points Q and P, respectively, creating equal intercepts on the axis. Calculate the distance between OQ and OP.

Then the focal length,  $f = 1/OP = 1/OQ = \dots$

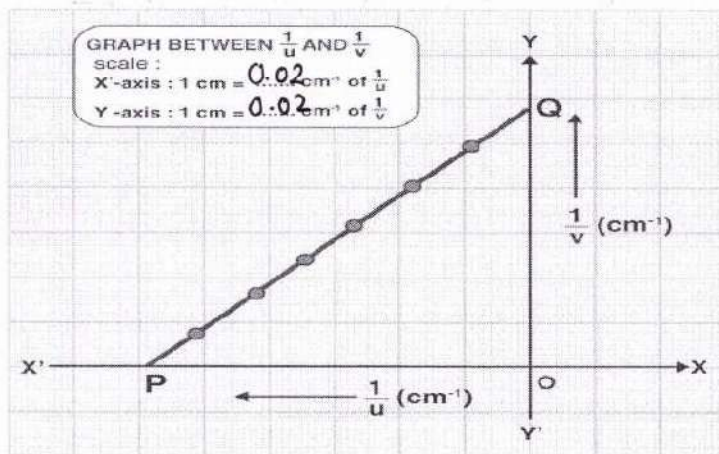

Graph between  $\frac{1}{u}$  and  $\frac{1}{v}$ . It is a straight line

### Result

The focal length of the convex as calculated from

1. Focal length from  $f = \frac{uv}{u-v}$
2.  $v \rightarrow u$  graph =  $\dots$  cm
3.  $\frac{1}{v} \rightarrow \frac{1}{u}$  graph =  $\dots$  cm

### Precautions

- Tips of the image needle and the object needle must lie at the exact height as the lens's centre.
- Parallax must be corrected from tip to tip by placing the eye at a distance minimum of 30 cm apart from the needle.
- The object needle must be positioned at such a distance that only an inverted and real image of the object needle is produced.
- Index correction for  $u$  and  $v$  must be applied.

## EXPERIMENT – 6

### Aim

To find the focal length of a convex mirror using a convex lens.

### Materials Required

- An optical bench with uprights for holding lens
- mirror and two needles
- two needles (pins)
- a thin convex lens
- a convex mirror
- index needle (may be a knitting needle or a pencil sharply pointed at both ends)
- a metre scale and a spirit level.

### Theory

The formation of image of an object  $AB$  by a convex mirror  $MM'$  (having a small aperture) in two different situations. The image formed by a convex mirror is virtual and erect.

Therefore, its focal length cannot be determined directly. However, it can be determined by introducing a convex lens in between the object and the convex mirror.

object  $AB$  is placed at point  $P'$  in front of a thin convex lens such that its real, inverted and magnified image  $A'B'$  is formed at position  $C$  on the other side of the lens.

Now a convex mirror is introduced between the convex lens and point  $C$  and so adjusted that the real and inverted image  $A'B'$  coincides with the object  $AB$  at point  $P'$ . This is possible if the light rays starting from the tip of the object, after passing through the lens, fall normally on the reflecting surface of the convex mirror and retrace their path.

Any normal ray (perpendicular) to a spherical surface has to be along the radius of that sphere so that point  $C$  must be the centre of curvature of the convex mirror.

Therefore, the distance  $PC$  is the radius of curvature  $R$  and half

of it would be the focal length of the convex mirror.

$$\text{That is, } f = \frac{PC}{2} = \frac{R}{2}$$

### Ray Diagram

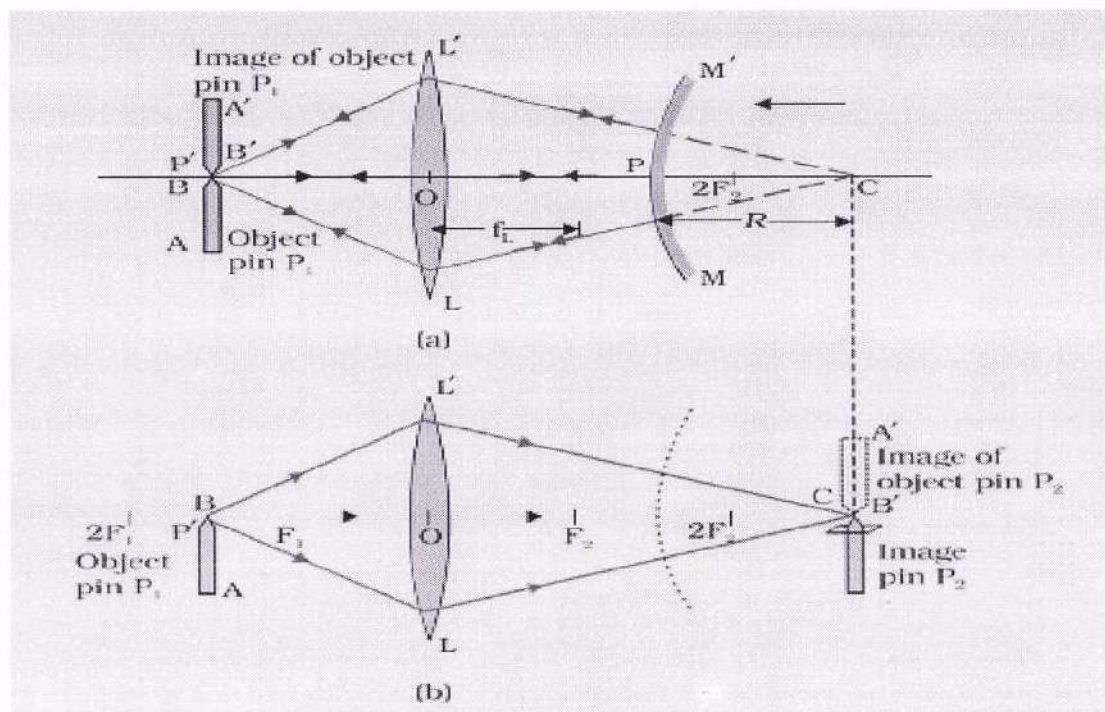

### Procedure

1. In case, if the focal length of the given thin convex lens is not known then approximate value of its focal length should be estimated first.
2. Place the optical bench on a rigid table or on a platform. Using the spirit level, make it horizontal with the help of levelling screws provided at the base of the bench.
3. Place the uprights mounted with pin  $P_1$  (object pin), convex lens  $LL'$ , and convex mirror  $MM'$  on the horizontal optical bench [Fig (a)].
4. Check that the lens, mirror, and pin  $P_1$  are vertically placed on the optical bench. Also verify that the tip of the pin, optical centre  $O$  of the convex lens  $LL'$ , and pole  $P'$  of the convex mirror  $MM'$  lie on the same horizontal straight line, parallel to the optical bench.
5. Determine the index correction between upright holding of the convex mirror and image pin respectively, using an index needle.
6. Place the object pin  $P_1$  from the convex lens  $LL'$  at a distance slightly greater than the focal length of the lens.

7. Adjust the position of the convex mirror MM' till the light rays reflected back from the mirror pass through the lens and form a real and inverted image coinciding with the object pin P<sub>1</sub>, as shown in Fig (a). This occurs when the rays starting from the tip of pin P<sub>1</sub>, after passing through the lens strike the mirror normally and are reflected back along their original paths. Remove the parallax between the image and object pins.
8. Read the position of uprights holding the object pin P<sub>1</sub>, convex lens LL', and convex mirror MM' and record the observations in the observation table.
9. Remove the convex mirror from its upright and fix image pin P<sub>2</sub> on it. Adjust the height of pin such that the tip of it also lies on the principal axis of the lens. That is, the tips of the pins P<sub>1</sub> and P<sub>2</sub> and the optical centre O of the convex lens, all lie on a straight horizontal line parallel to the length of the optical bench.
10. You may put a small piece of paper on image pin P<sub>2</sub> to differentiate it from the object pin P<sub>1</sub>.
11. Using the method of parallax and without changing the position of lens LL' and object pin P<sub>1</sub>, adjust the position of image pin P<sub>2</sub> on the other side of the lens so that it coincides with the real and inverted image of the object pin P<sub>1</sub> formed by the convex lens [Fig (b)]. Note the position of the image pin.
12. Repeat the experiment by changing the separation between the pin P<sub>1</sub> and lens LL' and the mirror MM'. In this manner, take 4-5 sets of observations.

### Observations

- Focal length of the convex lens,  $f$  (estimated/given) =  $15$  cm
- Actual length of the index needle,  $l = 0.5$  cm
- Observed length of the index needle  $l'$   
= Position of mirror upright - position of pin upright on the scale  
=  $0.5$  cm

## Observations Table

Sl. No.	Upright position of				Observed $R' = c - d$ (cm)	Focal length $f = \frac{R}{2}$ (cm)
	Object pin P1 $a$ (cm)	Convex lens LL' $b$ (cm)	Convex Mirror MM' $c$ (cm)	Image pin P2 $d$ (cm)		
1	80	122.8	42.8	42.8	0	21.4
2	90	131.0	41	41	0	20.5
3	10	111.2	41.2	41.2	0	20.7
4						
5						

## Calculations

Calculate the mean value of radius of curvature of the convex mirror  $R$ , and determine its focal length  $f = R/2 = \dots$  cm  
20.8

## Result

The focal length of the given convex mirror is  $f$  20.8 cm.  
Here  $f$  is mean value of the focal length.

## Precautions

- The uprights supporting the pins, lens and mirror must be rigid and mounted vertically.
- The apertures of the given convex lens and convex mirror should be small, otherwise the image formed will be distorted.
- Eye should be placed at a distance of about 25 cm or more from the image pin.
- Optical bench should be horizontal. The tips of pins, centre of convex lens and pole of the mirror should be at the same horizontal level.

## Sources of Error

- The tip of the inverted image of the object pin should just touch the tip of the image pin and must not overlap. This should be ensured while removing the parallax.
- Personal eye defects may make removal of parallax tedious.
- The convex mirror should preferably be front-coated. Otherwise multiple reflections may take place.

## EXPERIMENT – 7

### Aim

To determine the angle of minimum deviation for a given prism by plotting a graph between angle of incidence and angle of deviation.

### Materials Required

- A drawing board
- A white sheet of paper
- A prism
- Drawing pins
- Pencil
- A half-metre scale
- Office pins
- Protractor
- Graph paper

### Theory

Refraction takes place when a light ray travels from one medium to another resulting in deviation of the emergent ray from that of the incident ray.

Following is the refractive index of the material used in the prism:

$$n = \frac{\sin\left(\frac{A+D_m}{2}\right)}{\sin\left(\frac{A}{2}\right)}$$

Where  $D_m$  is the angle of minimum deviation and  $A$  is the angle of the prism.

### Ray Diagram

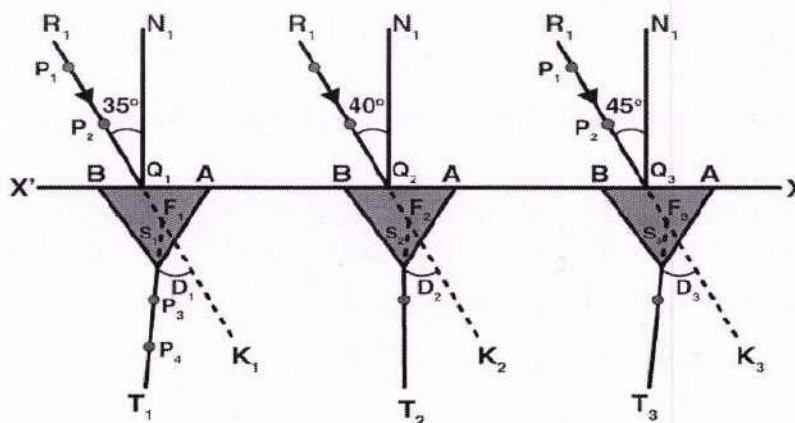

Refraction through prism at different angles

## Procedure

1. Place the white sheet of paper on the drawing board and fix it with the help of drawing pins.
2. XX' is the straight line which is drawn parallel to the length of the paper such that it is in the middle of the paper.
3. Mark points  $Q_1, Q_2, Q_3, \dots$  on the straight line XX' at a distance of 5 cm each.
4.  $N_1Q_1, N_2Q_2, \dots$  are the normals that are drawn on the points  $Q_1, Q_2, \dots$  as shown in the ray diagram.
5. Make angles of  $35^\circ, 40^\circ, \dots, 60^\circ$  by drawing straight lines  $R_1Q_1, R_2Q_2, \dots$  With respect to the normals.
6. To take one edge of the prism for all the observation, mark any corner of the prism as A.
7. Place the prism with its refracting face AB on the line XX' and on the point  $Q_1$  and also in the middle of AB.
8. Mark the boundary of the prism.
9. On the line,  $R_1Q_1$ , fix office pins vertically and mark them as  $P_1$  and  $P_2$ . the distance between these pins should not be less than 10mm.
10. Through prism face, AC, look for the images of the points  $P_1$  and  $P_2$ .
11. Close your left eye and with the right eye open, bring it in line with the two images.
12. Fix the other two office pins vertically and name them as  $P_3$  and  $P_4$ . These pins should be 10cm apart from each other.  $P_3$  and  $P_4$  should be in one straight with respect to the images of  $P_1$  and  $P_2$ .
13. Encircle the pricks of pins  $P_3$  and  $P_4$ .
14. For points,  $Q_2, Q_3, \dots$  for angle  $40^\circ, 45^\circ, \dots 60^\circ$ , repeat the steps 7 to 13.

### **To measure D in a different case**

1. To get emergent rays  $S_1T_1, S_2T_2, \dots$  draw straight lines through  $P_3$  and  $P_4$ .
2. Inward the boundary of the prism to produce  $T_1S_1, T_2, S_2, \dots$  so that they meet incident rays  $R_1Q_1, R_2Q_2, \dots$  at points  $F_1, F_2, \dots$
3. To obtain the angle of deviation  $D_1, D_2, \dots$  measure the angles  $K_1F_1S_1, K_2F_2, S_2, \dots$
4. Note these angles.

### **To measure angle A**

1. To get angle A, measure the  $\angle BAC$  in the boundary of the prism.
2. Record the observations.

## Observations

Least count of the protractor =  $\dots\dots\dots^\circ$  (degree)

Angle of the prism,  $A = \dots\dots\dots^\circ$  (degree)

## Observations Table

Sr no.	Angle of incidence $\angle i$	Angle of deviation $\angle D$
1	$35^\circ$	$31^\circ$
2	$40^\circ$	$37.8^\circ$
3	$45^\circ$	$42^\circ$
4	$50^\circ$	$43^\circ$
5	$55^\circ$	$48^\circ$
6	$60^\circ$	$45^\circ$

## Calculations

To plot the graph between  $\angle i$  and  $\angle D$ , take  $\angle i$  along the x-axis and  $\angle D$  along the y-axis.

Minimum deviation  $D_m$  can be found from the graph which would be corresponding to the lowest point in the graph.

Let the value of angle of minimum deviation,  $D_m = 42^\circ$

Then, refractive index of the material used in the prism:

$$n = \frac{\sin\left(\frac{A+D_m}{2}\right)}{\sin\left(\frac{A}{2}\right)} = 1.6$$

Graph between  $i$  and  $D$

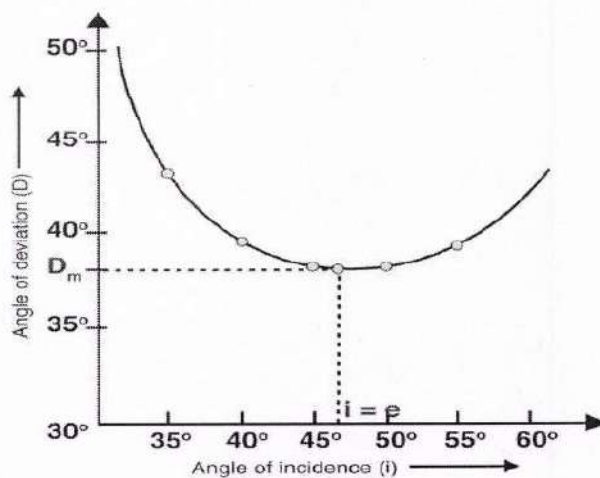

## Result

- The angle of minimum deviation,  $D_m = \dots 4.2^\circ$
- Refractive index of the material of the prism,  $n = \dots 1.6$
- The graph indicates that the angle of incidence increases, the angle of deviation first decreases to attain the minimum value of  $D_m$  and then increases as the angle of incidence increases.

## Precautions

- $35^\circ$ - $60^\circ$  is the angle of incidence that needs to be maintained.
- The placement of the pins must be vertical.
- The placement of two pins should be such that the distance is not more than 10mm.
- To represent incident and emergent rays arrowheads must be marked.
- The angle of prism used should be the same for all the observations.
- Position of the prism should not be disturbed for a given set of observations.

## Sources of Error

- The pricks made by the pins might be thick.
- There may be an error in measuring the values of the angles.

## EXPERIMENT – 8

### Aim

To draw the I - V characteristic curves of a p-n junction in forward bias and reverse bias.

### Materials Required

- A p-n junction diode (OA-79 or 1N4007)
- A resistor of value ( $3\Omega$ , 1/2W)
- One variable voltage power supply (0-12V)
- Voltmeter (0-12V)
- Milliammeter (0-200 mA)
- A plug key
- Connecting wires
- Sand paper
- A microammeter (0-200  $\mu$ A).

### Theory

**Forward bias:** When an external voltage is applied to a p-n junction diode in such a way that the p-side is at a higher potential with respect to the n-side, it is said to be forward biased.

**Threshold voltage or “Cut-in” voltage:** When the p-side is connected to the positive terminal of the battery and the voltage is increased, initially a negligible current flow till the applied voltage crosses a certain value. After, a characteristic voltage, the diode current increases significantly (exponentially), even for a very small increase in the diode bias voltage. This voltage is called the threshold voltage or cut-in-voltage of the diode.

**Reverse bias:** When the n-region of a p-n junction diode is at a higher potential with respect to the p-region, it is said to be reverse biased. In reverse bias, the p-side of the p-n junction diode is connected to the negative of the battery.

**Reverse saturation current:** As the applied voltage is increased in the reverse biased condition, starting from zero value, the current increases, but soon becomes constant. This current is very small (a few microamperes). It is called the reverse saturation current.

## Circuit Diagram

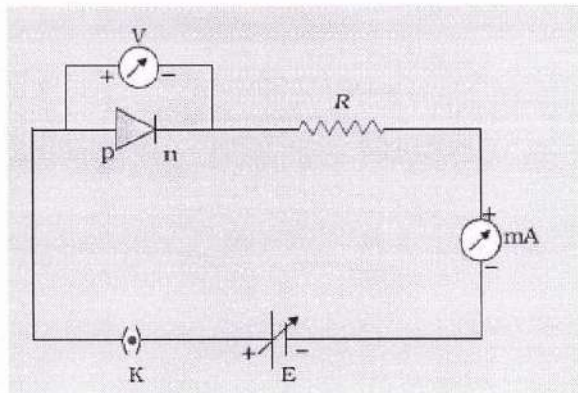

**(a) Forward biasing for a p-n junction diode**

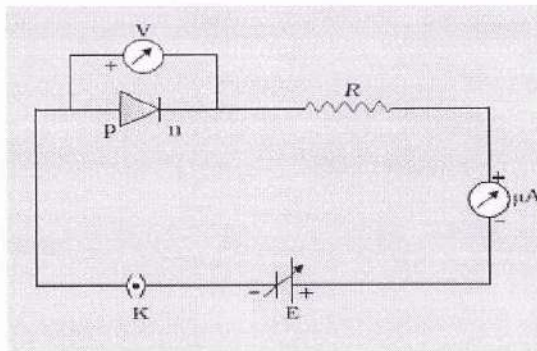

**(b) Reverse biasing for a p-n junction diode**

## Procedure

1. Note the range and least count of the given voltmeter (V), milliammeter (mA) and the microammeter ( $\mu\text{A}$ ).
2. Remove the insulating layers from the connecting wires and leads of diode using a sand paper.
3. Connect the variable voltage power supply, p-n junction diode, voltmeter, milliammeter, resistor and a plug key in a circuit as shown in Fig. (a)
4. Initially when the key is open, you would note at this stage, that no current is flowing through the circuit. Now close the key.
5. Give a small voltage to the circuit by slight and gentle turning of the power supply knob. Note the voltmeter reading across the diode and the corresponding milliammeter reading to find the current  $I$  flowing through the diode
6. Gradually, increase the applied voltage (in steps) in the circuit and note the corresponding voltmeter and milliammeter readings in Table (a). The value of current flowing through the diode would be negligibly small till the voltage across the diode exceeds the value of its *cut in or threshold voltage*. After the *cut-in voltage*, the variation in current will be rapid.
7. Once the threshold voltage is reached, vary the diode voltage very slowly (preferably in steps of 0.1V) noting the corresponding current  $I$  flowing through the diode. Continue increasing voltage till the current reaches the limit of the milliammeter.
8. Now disconnect the circuit and make the connections as shown in Fig.(b) for the reverse bias characteristics. Connect p-side of p-n junction diode to the negative terminal of the power supply and replace milli-

Ammeter with a microammeter. Gradually, increase the applied voltage (in steps) in the circuit and note the corresponding voltmeter and microammeter readings in Table (b).

In this part of experiment, with the given supply voltage you will get only flat portion of the reverse bias characteristic curve.

### CAUTION

Never increase the value of the voltage too much across the diode. Excessive current flow may damage the diode if it exceeds its limit. Maximum permissible current that can pass through the diode can be known from the technical data as specified by the manufacturer.

### Observations

1. p-n junction diode used (diode no.) = IC 583

#### 2. For forward biasing

(i) Range of the voltmeter = 0 V to 15 V

(ii) Least count of the voltmeter scale = 0.25 V

(iii) Range of the milliammeter = 0 mA to 100 mA

(iv) Least count of the milliammeter scale = 0.2 mA

#### 3. For reverse biasing

(i) Range of the voltmeter = 0 V to 15 V

(ii) Least count of the voltmeter scale = 0.25 V

(iii) Range of the microammeter = 0 μA to 100 μA

(iv) Least count of the microammeter = 0.2 μA

Table (a): Variation of forward current with voltage across the diode (forward bias)

Sr. No.	Forward voltage $V_f$ (V)	Forward current $I_f$ (mA)
1	0.10	0
2	0.20	0
3	0.30	0
-	-	-
-	-	-
20	0.75	12.45

4 to 9 Reversing  
Turn to Page

Table (b): Variation of reverse current with voltage across the diode (Reverse bias)

Sr. No.	Reverse voltage $V_r$ (V)	Reverse current $I_r$ ( $\mu$ A)
1	1	0
2	3	0
3	5	0
-	6	0
-	-	-
20	14	86

### Plotting Graph:

1. Plot a graph between forward voltage across the diode ( $V_f$ ) along the positive X-axis and current flowing through the diode ( $I$ ) along the positive Y-axis. The graph as shown in Fig(a) represents a typical  $I$ - $V$  characteristic of a silicon diode used. Locate the knee and determine the cut-in voltage.
2. Now plot the reverse voltage ( $V_r$ ) along the negative X-axis and the corresponding current (in  $\mu$ A) along the negative Y-axis as shown in Fig (b). Determine the reverse saturation current.

### **Typical I-V characteristics of a silicon diode in forward biasing and reverse biasing**

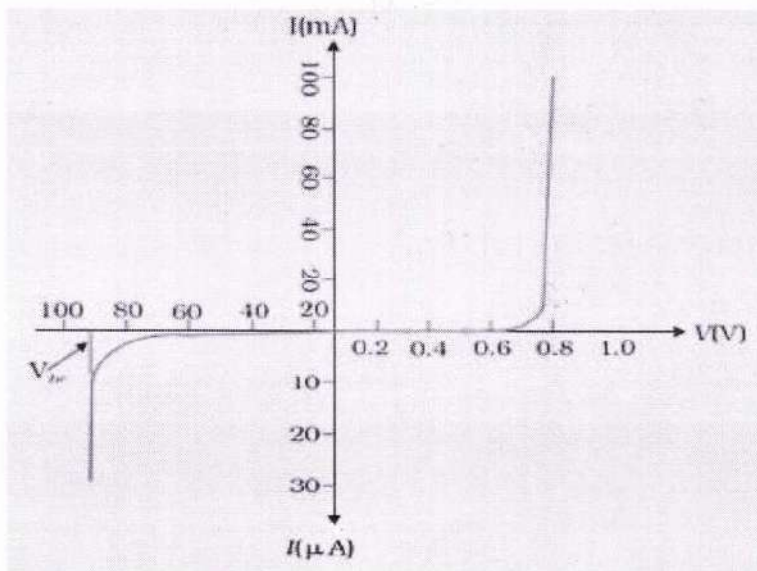

### Result

- 12.47
- A. The value of cut-in voltage for the given diode is 0.55 V.
  - B. The reverse saturation current for the given diode is 7  $\mu$ A.

## Precautions

1. The connections should be neat, clean and tight.
2. Key should be used when the circuit is being used.
3. Beyond breakdown, forward bias voltage should not be applied.
4. Beyond breakdown, reverse bias voltage should not be applied.

### ① (Forward Bias)

Forward voltage $V_f$ (V)	Forward current $I_f$ (mA)
0.10	0
0.20	0
0.30	0
0.40	0.02
0.50	0.29
0.55	1.21
0.60	2.9
0.65	7.63
0.70	9.73
0.75	12.47

### ② (Reverse Bias)

Reverse voltage $V_r$ (V)	Reverse current $I_r$ (mA)
0	0
1	0
2	0
3	0
4	0
5	0
6	0
7	1
8	2
9	5
10	18
11	28
12	50
13	70
14	86
15	Constant

## ACTIVITY – 1

### Aim

To measure resistance, voltage (AC/DC), current (AC) and check continuity of a given circuit using multimeter.

### Apparatus and material

- Three carbon resistors
- one standard resistance coil
- a battery eliminator with tapping (2 V, 4 V and 6 V)
- a step-down transformer (6-0-6 V) with two tapping (2 V and 4 V)
- a resistor of  $100\Omega$
- a plug key and multimeter.

### Theory

#### **Multimeter**

- It is a single measuring device acting as an Ammeter, a Voltmeter and an Ohmmeter. For this reason, it is also called **AVO** meter.
  - It can measure alternating as well as direct current and alternating as well as direct voltage in addition to resistance. For this purpose, its panel is divided into five different sections. There are many ranges in each section so that it can measure from micro ( $10^{-6}$ ) to mega ( $10^6$ ) units. Rotation of a knob changes the section and the range in one section.
  - Rotation of knob for change in ammeter range, brings shunt resistances of different values in circuit in parallel with the coil.
  - Rotation of knob for change in voltmeter range, brings series resistances of different values in circuit in series with the coil.
  - Rotation of knob for change in ohmmeter range, brings different resistances in circuit in series with the multimeter cell.
1. Carbon resistors are frequently used in electrical and electronic circuits and their values vary over a very wide range. A colour code is used to indicate the value of the resistance.

2. A carbon resistance has four different concentric coloured rings or bands on its surface. The first three bands a, b and c determine the value of the resistance and the fourth band d gives the percentage of accuracy called tolerance. The resistance of carbon resistor  $R = (ab \times 10^c \pm T \%) \Omega$ .
3. To read the value of carbon resistance, the following sentence is found to be of much more helpful.

**B B R O Y Great Britain Very Good Wife**  
**0 1 2 3 4 5 6 7 8 9**

The bold face letter B, B, R, O, Y, G, B, V, G and W, in above sentence correspond to the colours Black, Brown, Red, Orange, Yellow, Green, Blue, Violet, Grey and White respectively for *a* and *b*, while for the third *c*, they correspond to the multipliers  $10^0$ ,  $10^1$ ,  $10^2$ ,  $10^3$ ,  $10^4$ ,  $10^5$ ,  $10^6$ ,  $10^7$ ,  $10^8$  and  $10^9$  respectively.

4. The following table provides the colour code for the carbon resistors:

Letter (helpful to memory)	Colour	Figure a, b	Multiplier (c)	Colour (for the fourth band)	Tolerance T
B	Black	0	$10^0$	Gold	5%
B	Brown	1	$10^1$	Silver	10%
R	Red	2	$10^2$	No colour	20%
O	Orange	3	$10^3$		
Y	Yellow	4	$10^4$		
G	Green	5	$10^5$		
B	Blue	6	$10^6$		
V	Violet	7	$10^7$		
G	Grey	8	$10^8$		
W	White	9	$10^9$		
	Gold		$10^{-1}$		
	Silver		$10^{-2}$		

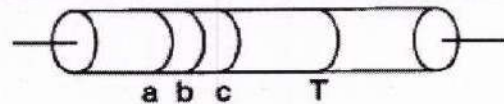
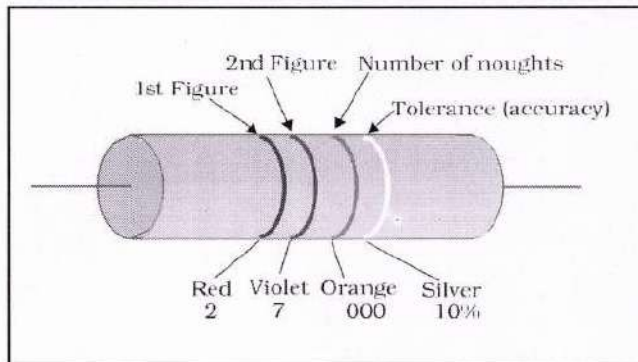

**(b) D.C. Voltage**

1. Select a D.C. source of potential difference, 6 V battery eliminator or a battery.
2. Plug the probes black in com and red in +.
3. Select D.C. volt, by turning the selector switch to range 10 V D.C. volts,
4. Touch and press other ends of probes such that red is on battery terminal marked + and black on and not the reading.
5. Insert red probe in terminals marked 4 V, 2 V in succession and note readings.

**(c) A.C. Volts**

1. Turn the selector A.C. (200 Volt).
2. Touch and press the probes other ends to two terminals of A.C. source of potential drop and note the reading.
3. Use red probe in terminals 4 V and 2 V in succession and record the reading.

**Precautions**

1. Instructions for handling the multimeter should be gone through thoroughly as it is a very handy instrument and is likely to get damaged if carelessly or ignorantly used.
2. Select the appropriate parameter current, voltage or resistance to the measured and set it on appropriate range.
3. If range of the parameter measured is not known, start with maximum. For measuring V, never connect more than maximum 600 V.

## ACTIVITY – 2

### Aim

To assemble a household circuit comprising three bulbs, three (on/off) switches a fuse and a power source.

### Apparatus and material

#### **Apparatus:**

No apparatus required in assembling a circuit.

#### **Material:**

Three bulbs (6 V, 1W) each, fuse of 0.6 A, main switch a power supply (battery or eliminator), three (on/off) switches flexible connecting wire with red and black plastic covering, a fuse wire.

#### **Supplementary:**

Main electric board with a two-pin socket and main switch.

### Theory

Electricity supplied to us for domestic purposes is 220 V A.C. and 50 Hz. The household circuit, all appliances are connected in “parallel” with mains. The switches are connected in series with each appliance in live wire. 5 A switches are required for normal appliances like, bulbs, fluorescent tubes fans etc. 15 A sockets and switches are required for heavy load appliances like **refrigerator, air conditioner, geyser, hot plates** etc. All appliances must have three wires called live, neutral and the earth. Total power consumption ‘P’ at a time

$$P = P_1 + P_2 + P_3 + \dots$$

where  $P_1, P_2, P_3$  are the powers drawn by appliances.

To protect the appliances from damage when unduly high currents are drawn fuse of little high rating, 10 to 20% higher than the current normally drawn by all appliances. For further safety, a suitable value MAINS FUSE like rating 32 A is connected in series with supply source.

## Diagram

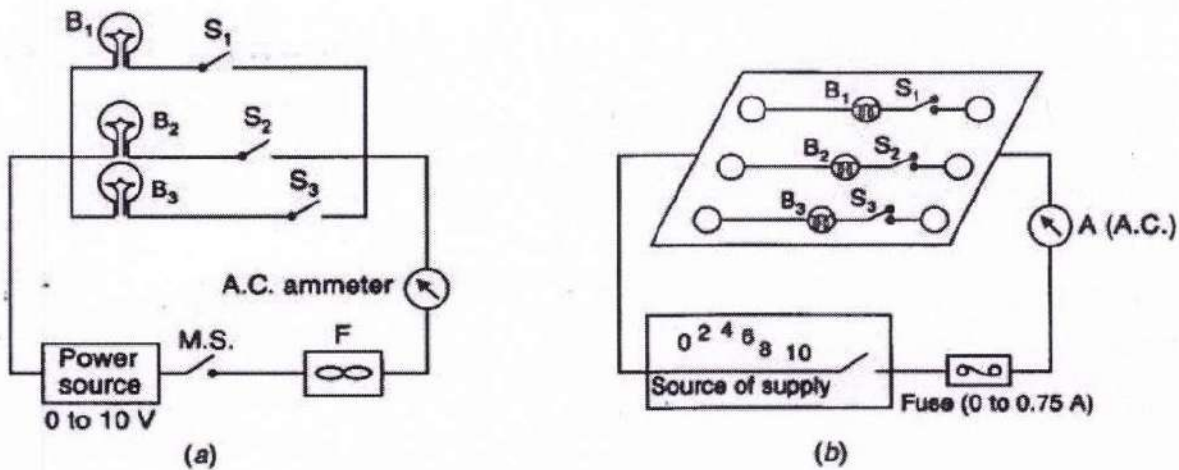

(a) Circuit diagram, (b) Actual layout.

## Procedure

1. Connect the bulbs B1, B2 and B3 in series with switches S1, S2 and S3 respectively and connect each set of B-S in parallel with each other.
2. Connect main supply to a step-down transformer (battery eliminator) to get required voltage from 0 to 10 V (0, 2, 4, 6, 8 and 10 V).
3. Connect the mains fuse M.S. in series with the power supply (battery eliminator).
4. Connect an A.C. ammeter in series with the B-S set.
5. Connect one end of power supply to one end of B-S set.
6. Check the circuit one again to ensure that household circuit is complete.
7. Gradually increase the current to 0.75 A, the fuse must bum off at about 0.6

## ACTIVITY – 3

### Aim

To assemble the components of a given electrical circuit.

### Apparatus and material

#### **Apparatus:**

A voltmeter and an ammeter of appropriate range, a battery, a rheostat, one way key.

#### **Material:**

An unknown resistance or resistance coil, connecting wires, a piece of sand paper.

### Diagram

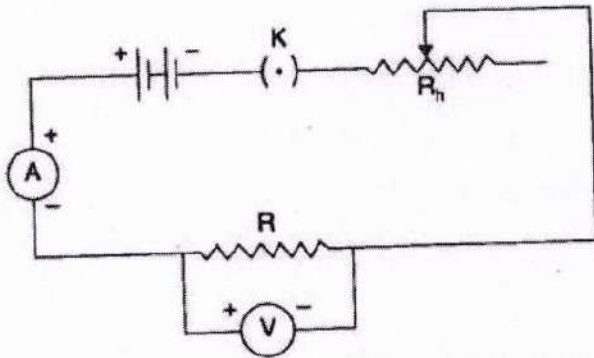

### Procedure

1. Connect the components (Resistors, inductors etc.) in series with each other as shown in diagram and then in series with the battery.
2. Connect the ammeter in series with the circuit, to measure the current.
3. Connect the voltmeter in parallel to the resistor, to measure the potential difference.
4. Connect the switch in series with the battery.
5. Assembly of the electrical components in electric circuit is complete.

## ACTIVITY – 4

### Aim

To identify a diode, an LED, a transistor, an IC, a resistor and a capacitor from a mixed collection of such items.

**Apparatus:** Multimeter.

**Material:** Above mixed collection of items.

### Theory

**For identification, appearance and working of each item will have to be considered.**

1. A diode is a two terminal device. It conducts when forward biased and does not conduct when reverse biased. It does not emit light while conducting. Hence, it does not glow.
2. A LED (light emitting diode) is also a two terminal device. It also conducts when forward biased and does not conduct when reverse biased. It emits light while conducting. Hence, it glow.
3. A transistor is a three terminal device. The terminals represent emitter (E), base (B) and collector (C).
4. An IC (integrated circuit) is a multi-terminal device in form of a chip. [See figure (UM 3482 IC Tone Generator)]
5. A resistor is a two terminal device. It conducts when either forward biased or reverse biased. (In fact there is no forward or reverse bias for a resistor). It conducts even when operated with A.C. voltage.
6. A capacitor is also a two terminal device. It does not conduct when either forward biased or reverse biased. When a capacitor is connected to a D.C. source, then multimeter shows full scale current initially but it decay to zero quickly. It is because that initially a capacitor draw a charge.

The components to be identified are shown in figure.

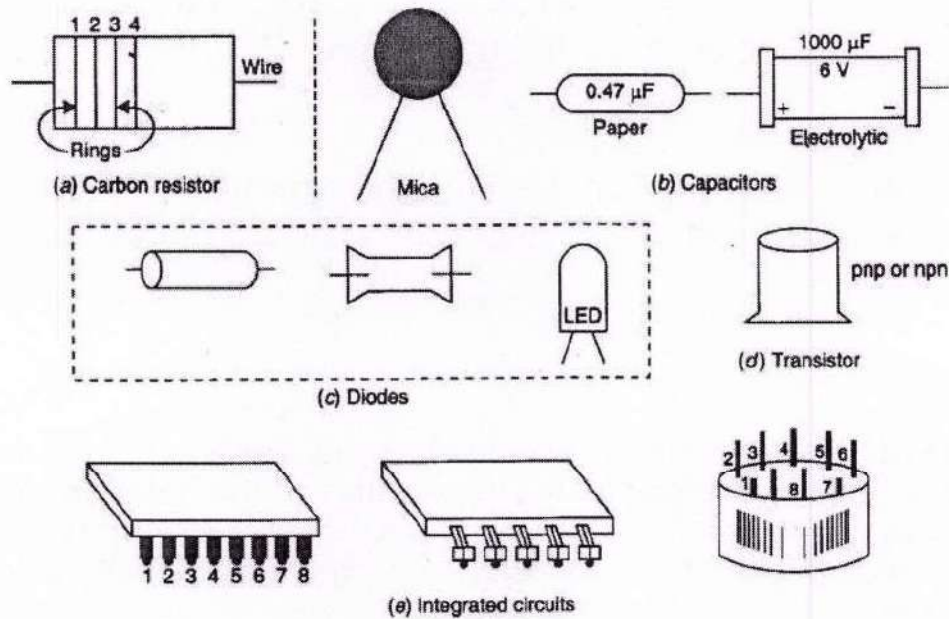

Fig. Some of the commonly available integrated circuits (ICS).

## Procedure

1. If the item has four or more terminals and has form of a chip, it is an IC (integrated circuit).
2. If the item has three terminals, it is a transistor.
3. If the item has two terminals, it may be diode, a LED, a resistor or a capacitor. To differentiate proceed as ahead.
4. Put the selector on resistance R of multimeter for checking the continuity. The probe metal ends are inserted in terminal marked on the multimeter as common and P (or + ve).

## ACTIVITY – 5

### Aim

To study the effect of intensity of light (by varying distance of the source) on a LDR (Light Dependent Resistor).

### Apparatus

LDR, two power supplies (12 V each), key, milliammeter (0-500mA), voltmeter (0-10V), a resistance of  $47\Omega$ , a 12 V lamp, connecting wires.

### Theory

Light dependent resistor or a photoresistor is a device that is sensitive to light. Its resistance varies according to the intensity of light incident on it. It is made from a semiconductor material with light resistors to have light sensitive properties, one such materials is, cadmium sulphide.

Snake-like tracks are made of cadmium sulphide on thin metal films. LDR has a high resistance due to the fact that majority of electrons are locked into the crystal lattice and not free to move.

As light falls on the lattice, some of the electrons get sufficient energy to break free the crystal lattice to conduct electricity. A typical LDR has a resistance of 1 M in total darkness and a few hundred ohm resistance in bright light.

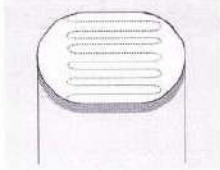

A Light Dependent Resistance (LDR)

### Diagram

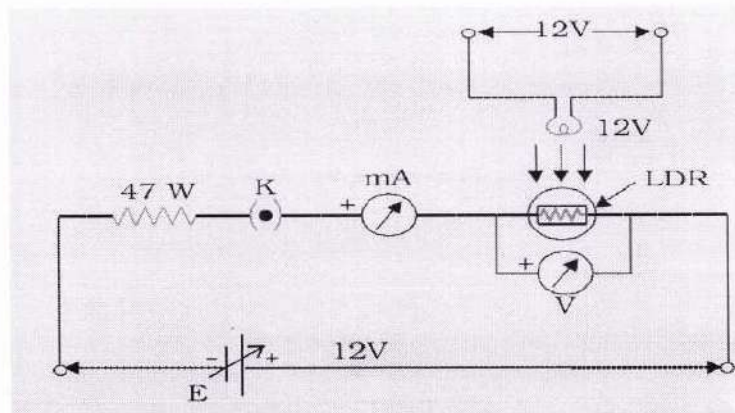

A Light Dependent Resistance (LDR)

### Procedure

1. Assemble the circuit as shown in Fig.
2. First keep the lamp switched off. Plug in the key K.
3. Observe and record voltmeter and milliammeter readings.
4. Calculate the reference measurement of LDR resistance  $R_0$ .
5. Add this value of resistance to all further measurements. This ensures that background illumination has been taken into account.
6. Set up a 12 V lamp on a fixed stand in vertical position facing LDR. Adjust LDR normally below the lamp at about 10 cm (say).
7. Observe milliammeter and voltmeter readings.

### Conclusion

As distance increases, intensity of incident light decreases and resistance of LDR increases.

### Precaution

1. LDR is placed normally to the light source so that angle of incidence of light rays remain constant and normal throughout the experiment.
2. All the connections should be made tight.

## ACTIVITY – 6

### Aim

To observe diffraction of light due to a thin slit.

### Apparatus

- Two razor blades
- Adhesive tapes
- A screen a source of monochromatic light (laser pencil) black paper
- A glass plate

### Theory

Diffraction is a phenomenon of bending of light around the corners or edges of a fine opening or aperture. Diffraction takes place when order of wavelength is comparable or small to the size of slit or aperture.

The diffraction effect is more pronounced if the size of the aperture or the obstacle is of the order of wavelength of the waves. The diffraction pattern arises due to interference of light waves from different symmetrical points of the same wave-front.

The diffraction pattern due to a single slit consists of a central bright band having alternate dark and weak bright bands of decreasing intensity on

For diffraction,  $d \sin \theta = n\lambda$

Here  $d$  = size of aperture or slit

$\theta$  = angle of diffraction

$n$  = order of diffraction

$\lambda$  = wavelength of light.

both sides.

### Diagram

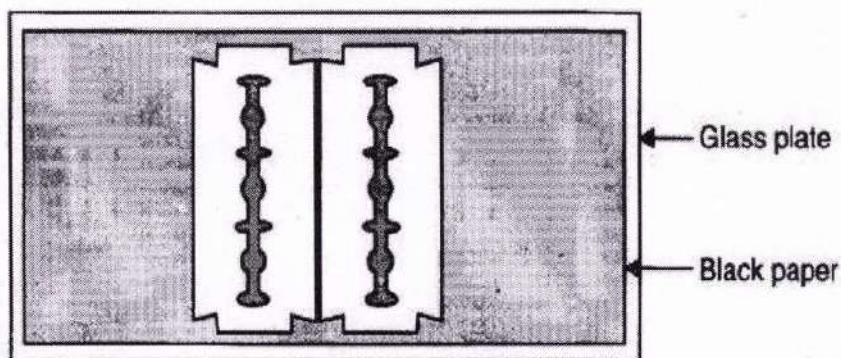

A thin slit made by using two razor blades, black paper and a glass plate.

## Procedure

1. Fix the black paper on the glass plate by using adhesive.
2. Place two razor blades so that their sharp edges are parallel and extremely close to each other to form a narrow slit in between.
3. Cut the small slit in between the sharp edges of blades and place at a suitable distance from a wall or screen of a dark room.
4. Throw a beam of light on the slit by the laser pencil.

## Conclusion

When light waves are incident on a slit or aperture then it bends away (spread) at the corners of slit showing the phenomena of diffraction of light.

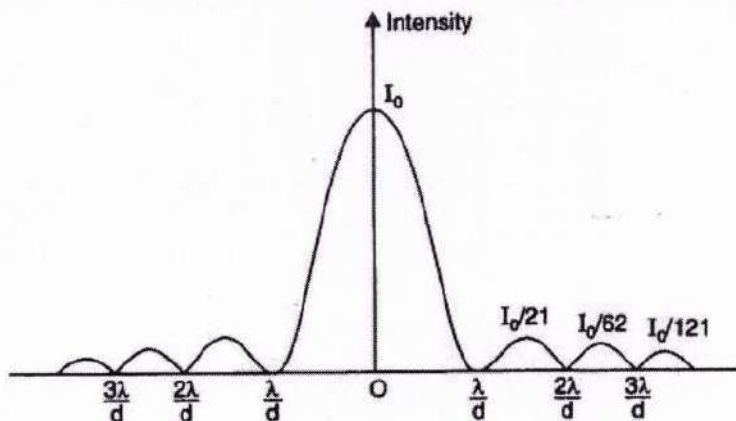

## Precaution

1. Air gaps should not be left between glass plates and black paper.
2. The razor blades should be placed extremely closed as possible.
3. Diffraction pattern should be seen on a wall of a dark room.
4. A point source of monochromatic light like laser torch should be used
5. A diffraction pattern of alternate bright and dark bands is seen on the wall.

# EXPERIMENT:- I

- Mrs. Hetal P. Panchal  
(M.Sc, B.Ed).

Scale Value :-

X-axis :-  $1\text{cm} = 0.05\text{V}$

Y-axis :-  $1\text{cm} = 0.2\text{A}$

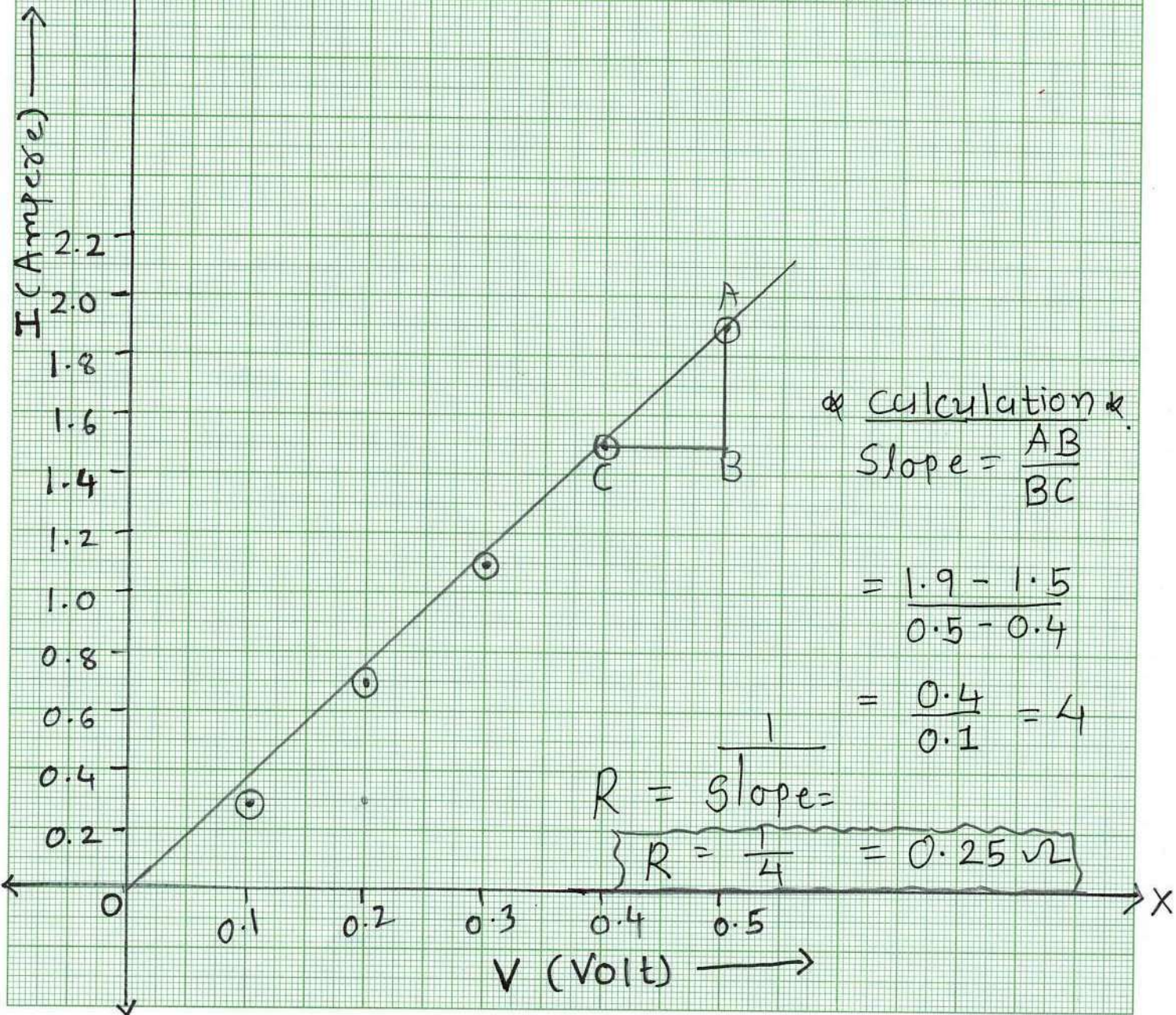

# EXPERIMENT:-5

$v \rightarrow u$

①

Scale value:

X'-axis: 1 cm = 5 cm of  $u$

Y-axis: 1 cm = 5 cm of  $v$

$$f = \frac{OB}{2} = \frac{OC}{2}$$

$$f = \frac{20 \cdot 2}{2}$$

$\therefore f = \underline{20} \text{ cm}$

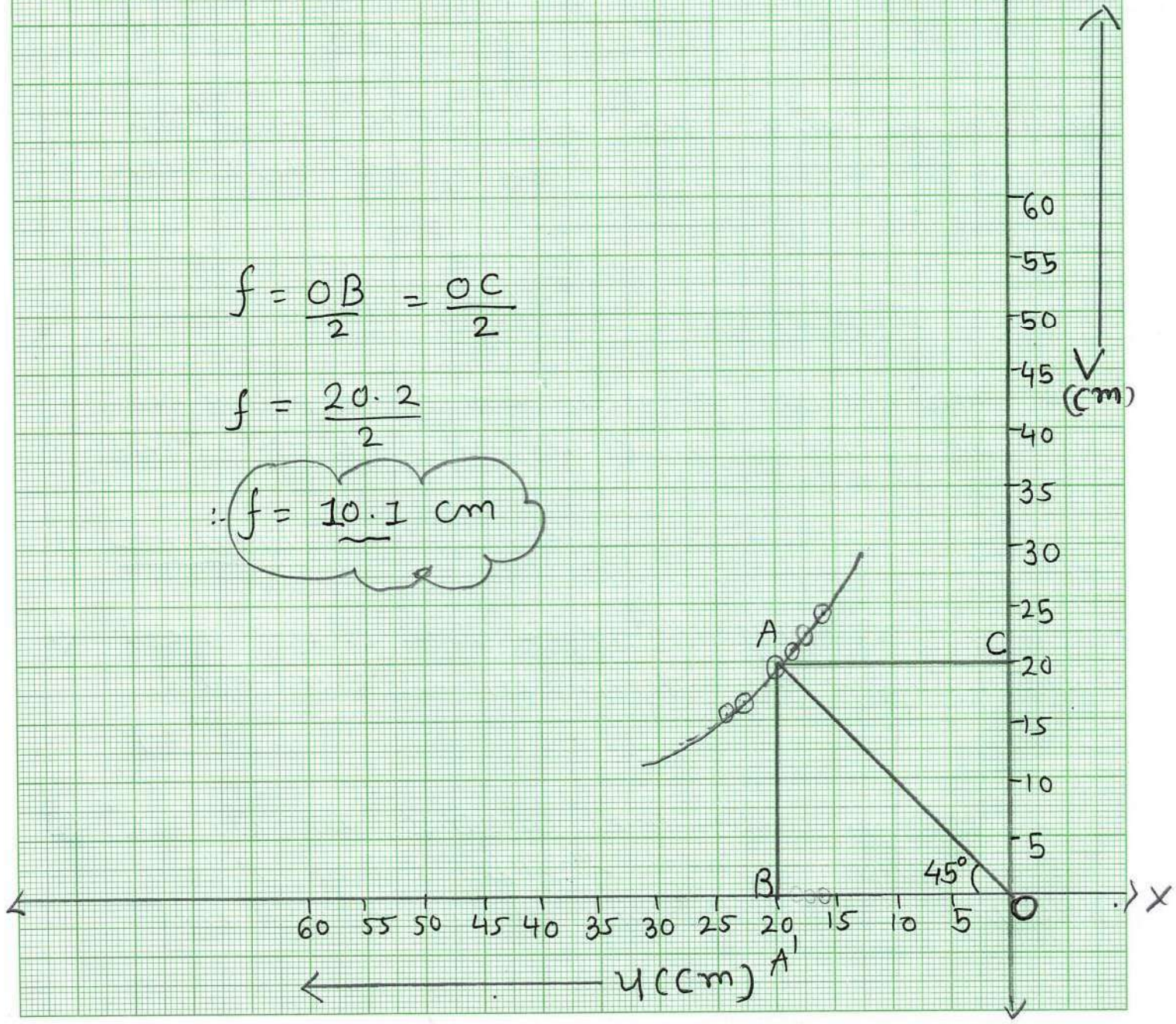

# EXPERIMENT:- 5 $\frac{1}{v} \rightarrow \frac{1}{u}$ (2)

Scale:-

$$X\text{-axis} = 1 \text{ cm} = \underline{0.02} \text{ cm}^{-1} \frac{1}{u}$$

$$Y\text{-axis} = 1 \text{ cm} = \underline{0.02} \text{ cm}^{-1} \frac{1}{v}$$

$$f = \frac{1}{OP} = \frac{1}{OQ} = \underline{10.1} \text{ cm}$$

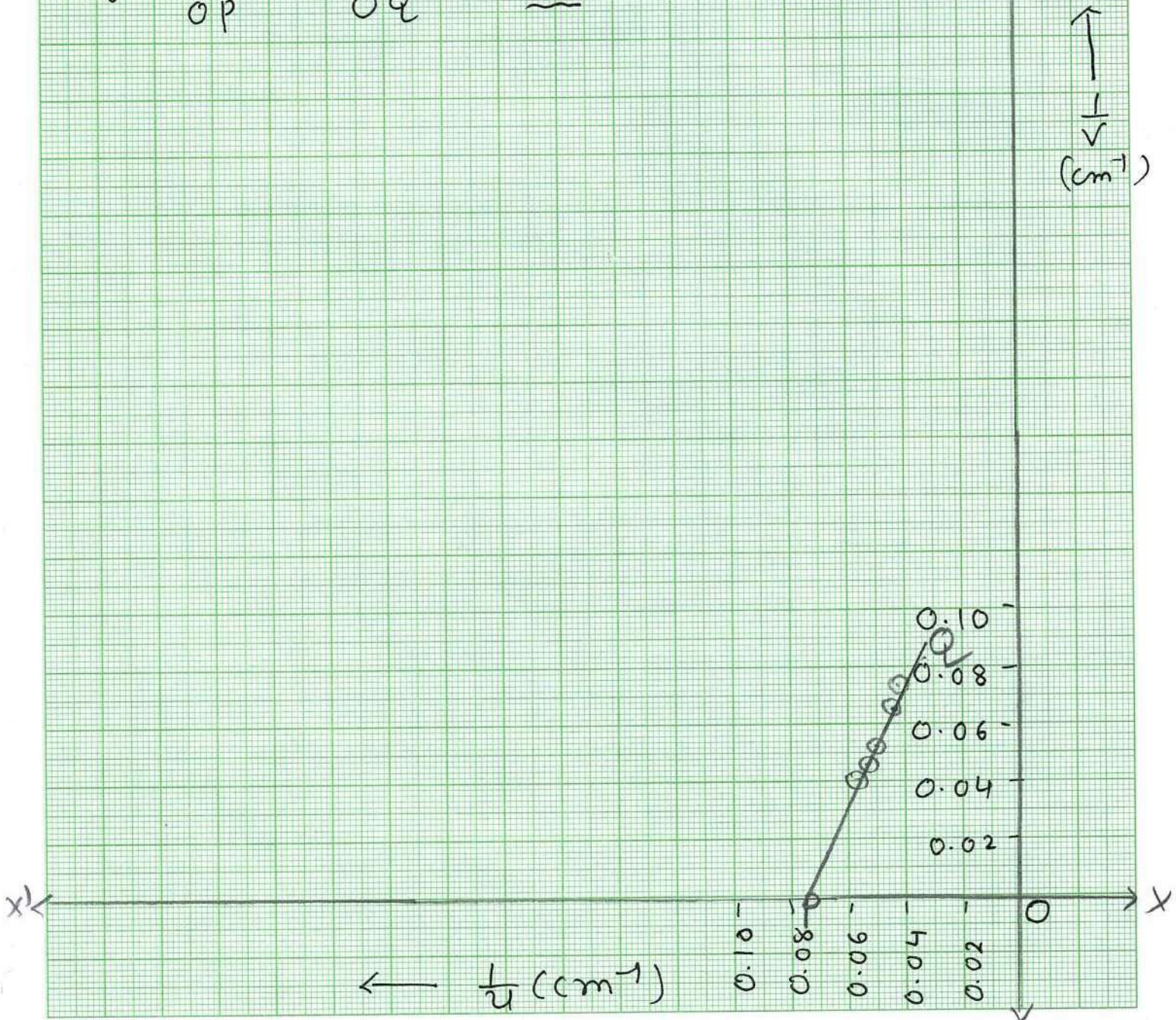

# EXPERIMENT:- 7

Scale:-

$$X\text{-axis} = 1\text{cm} = \underline{5^\circ}$$

$$Y\text{-axis} = 1\text{cm} = \underline{5^\circ}$$

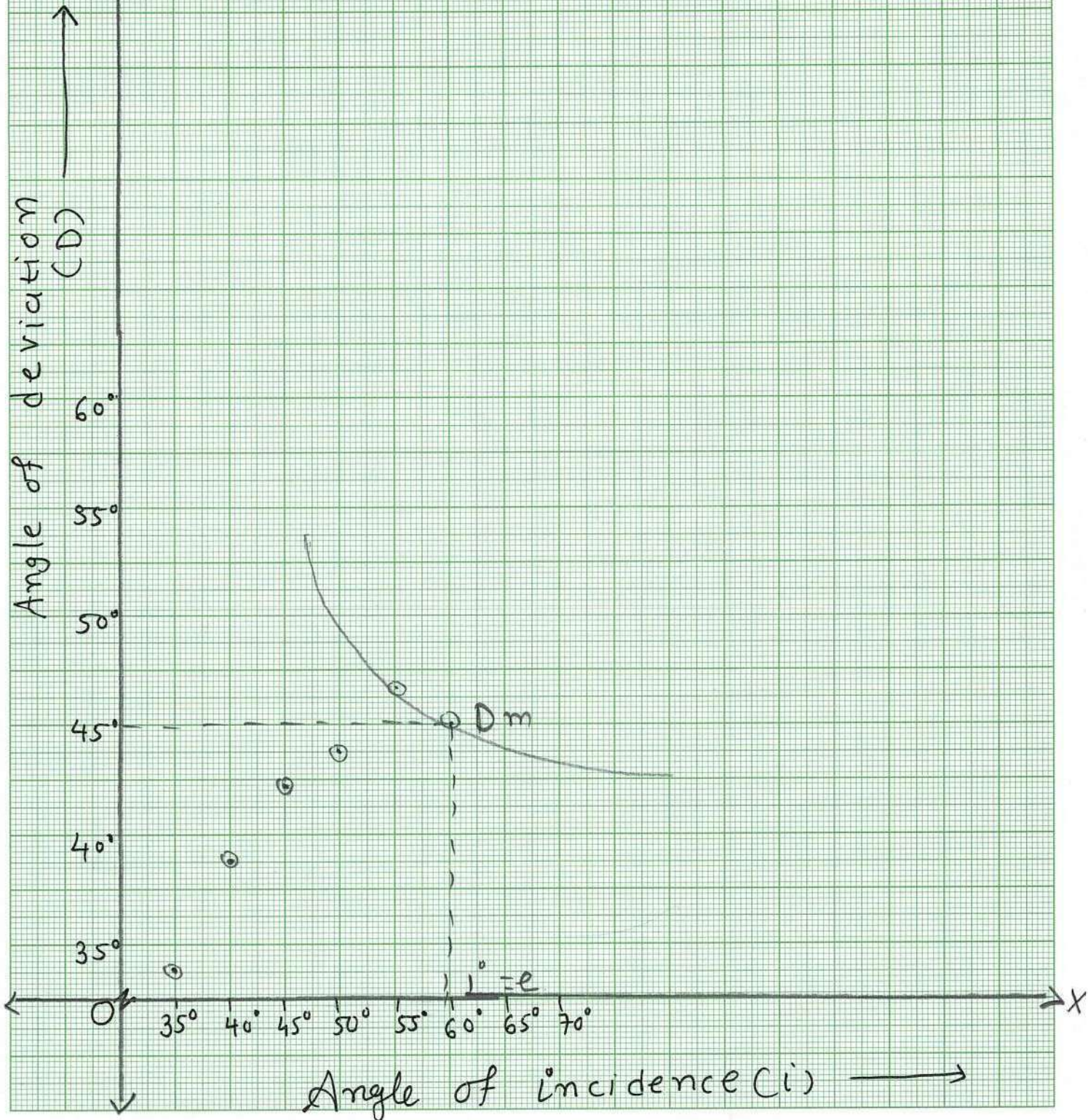

# EXPERIMENT :- 8

$I (mA)$

I-V Characteristics  
of a Silicon diode

in forward biasing  
& Reverse biasing

